



SANKET ELECTROTECH

AC Drive, Model : SET400G



- **Universal AC Drive, covering more than 90% applications**
- **Powerful current vector control performance, low noise, excellent energy-saving effect**
- **Perfect software and hardware protection function**
- **Double line display**
- **Strong anti - interfacing ability**
- **stable and reliable operation of the system**
- **Support user programmable control card**

Wiring diagram of three-phase

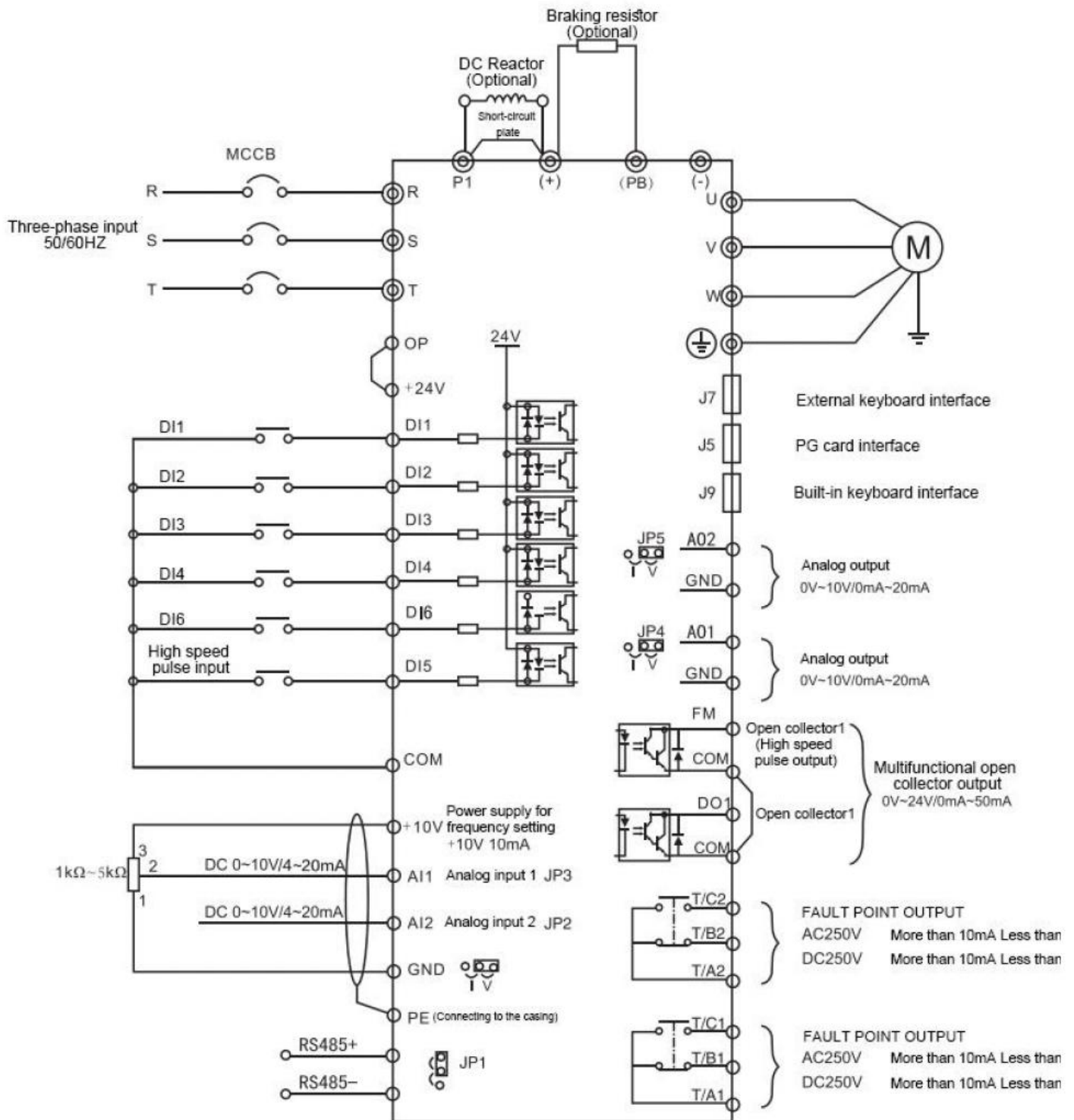

1) Terminal \circ represents the main circuit terminal and \circ represents the control circuit terminal.

2) 1.5kW~22kW built-in brake unit is standard configuration, without additional installation

3) The braking resistor is selected according to the user's needs, as detailed in the selection guide for braking resistors.

Electrical Specification

Specification and model	Rated output current(A)	Adaptive motor power(kw)	Height(H) Width(W) Depth(D) (mm)
SET400G-1R5G/2R2G	3.8/5.1	1.5/2.2	186*125*177
SET400G-2R2G/4R0P	5.1/9	2.2/4	
SET400G-4R0G/5R5P	9/13	4/5.5	248*160*192
SET400G-5R5G/7R5P	13/17	5.5/7.5	
SET400G-7R5P/11P	17/25	7.5/11	
SET400G-11G/15P	25/32	11/15	322*208*200
SET400G-15G/18.5P	32/37	15/18.5	
SET400G-18.5G/22P	37/45	18.5/22	
SET400G-22G/30P	45/60	22/30	
SET400G-30G/37P	60/75	30/37	
SET400G-37G/45P	75/91	37/45	463*285*243
SET400G-45G/55P	91/112	45/55	
SET400G-55G/75P	112/150	55/75	600*385*280
SET400G-75G/90P	150/176	75/90	
SET400G-90G/110P	176/210	90/100	
SET400G-110G/132P	210/253	100/132	700*473*322
SET400G-132G/160P	253/304	132/160	
SET400G-160G/185P	304/340	160/185	
SET400G-185G/200P	340/377	185/200	930*579*395
SET400G-200G/220P	377/426	200/220	
SET400G-220G/250P	426/465	220/250	
SET400G-250G/280P	465/520	250/280	1060*650*395
SET400G-280G/315P	520/585	280/315	
SET400G-315G/355P	585/650	315/355	
SET400G-355G/400P	650/725	355/400	
SET400G-400G/450P	725/820	400/450	1360*800*405
SET400G-450G/500P	820/860	450/500	
SET400G-500G/550P	860/950	500/550	
Note : SET400G series panel opening size: 147mm high and 79mm wide			

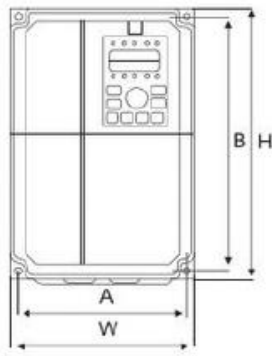

Figure 2-3 Dimensions below 22kw plastic model

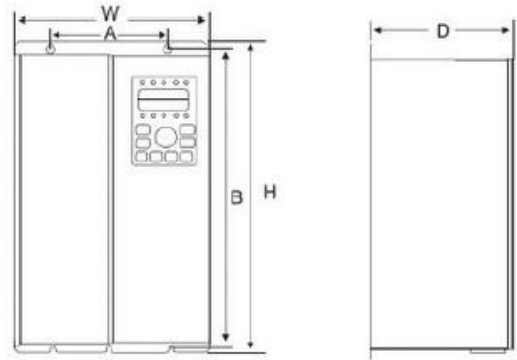
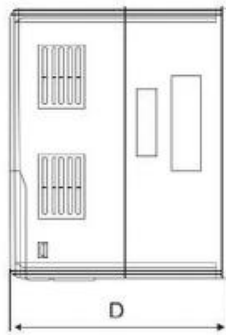

Figure 2-4 Boundary Dimensions of 30-500KW

2-4 Appearance and installation hole size

Power(kw)	A(mm)	B(mm)	H(mm)	W(mm)	D(mm)	Mounting hole diameter (mm)	Remark
	Installation dimension		Overall dimension				
1.5-4	113	172	186	125	177	5	
5.5-11	148	236	248	160	192	5	
15-22	190	305	322	208	200	6	
30-37	235	447	463	285	243	6.5	
45-75	260	580	600	385	280	7	
90-132	343	678	700	473	322	9	
160-200	449	903	930	579	395	12.5	
220-315	420	1030	1060	650	395	12.5	
355-450	520	1300	1360	800	405	12.5	
500	700	1130	1175	840	415	12.5	